



WMT-06 Wall Mount Programmable Fireplace Remote Control Installation and Operation Instructions:

The Acumen WMT-06 Programmable Remote Control is designed for use with gas fireplace and stoves using a millivolt valve.

The WMT-06 Transmitter is a six-button Wall Mount transmitter, which is used as a programmable thermostat to turn the gas on and off. The display of the transmitter shows the clock, current room temperature and the low battery indicator.

Installation Precautions:

The WMT-06 Programmable Remote Control is tested safe when installed in accordance with this installation manual. It is your responsibility to read all instruction before starting installation and to follow these instructions carefully during installation.

The WMT-06 Programmable Remote Control **MUST** be installed by a qualified service technician.

The WMT-06 Programmable Remote Control is carefully engineered and **MUST** be installed only as specified. If you modify it or any of its components, you may possibly cause a fire hazard.

FCC Requirements

Warning: Changes or modifications to this unit not expressly approved by the party responsible for compliance could void the user authority to operate the equipment. This equipment has been tested and found to comply with the limits for a Class B digital device, pursuant to Part 15 to the FCC Rules. These limits are designed to provide reasonable protection against harmful interference in a residential installation. This equipment generates, uses, and can radiate radio frequency energy and, if not installed and used in accordance with the instructions, may cause harmful interference to radio communications. However, there is no guarantee that interference will not occur in a particular installation. If this equipment does cause harmful interference to radio or television reception, which can be determined by turning the equipment off and on, the user is encouraged to try to correct the interference by one or more of the following measures:

- Reorient or relocate the receiver antenna.
- Increase the separation between the equipment and receiver.
- Connect the equipment into an outlet on a circuit different from that to which the receiver is connected.
- Consult the dealer or an experienced radio TV technician for help.

Canadian Equipment Requirements

This digital apparatus does not exceed the (class A/Class B)* limits for radio noise emissions from digital apparatus set out in the Radio Interference Regulations of the Canadian Department of Communications. Le présent appareil numérique n'met pas de bruits radioélectriques dépassant les limites applicables aux appareils numériques (de la class A/de la class B)* prescrites dans le Règlement sur le brouillage radioélectrique édicté par le ministère des Communications du Canada.

This device complies with RSS-210 of Industry and Science Canada. Operation is subject to the following two conditions : (1) this device may not cause interference, and (2) this device must accept any interference, including interference that may cause undesired operation of the device.

All wiring should be done by a qualified electrician and shall be in compliance with local codes and with the National Electric Code ANSI/NFPA No. 70-current (In the United States), or with the current CSA C22.1 Canadian Electric Code (in Canada).

1 Installation Instruction

1.1 Installing the Receiver

- 1 Make sure the slide switch on the Remote Receiver is at the OFF position.
- 2 Connect the leads to the millivolt generator and the main burner to the output cable of the Remote Receiver as shown in Figure 1 (or Figure 2 if the optional Emergency Switch is used).

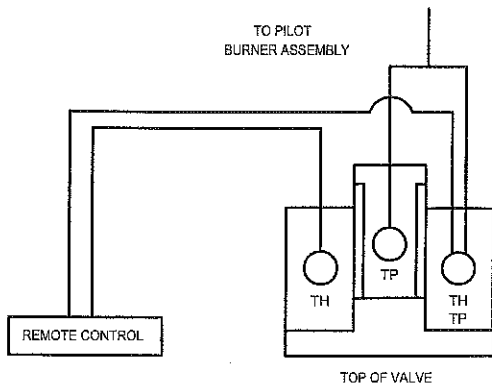

Figure 1

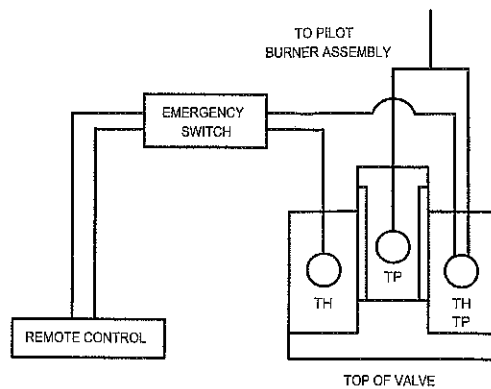

Figure 2

3 Installing the Remote Receiver to a Wall Mount:

- Secure the Remote Receiver to the Wall Mount. See Figure 3.
- Use the screws provided to secure the face plate to the Remote Receiver.

Installation of the Receiver to a Junction Box

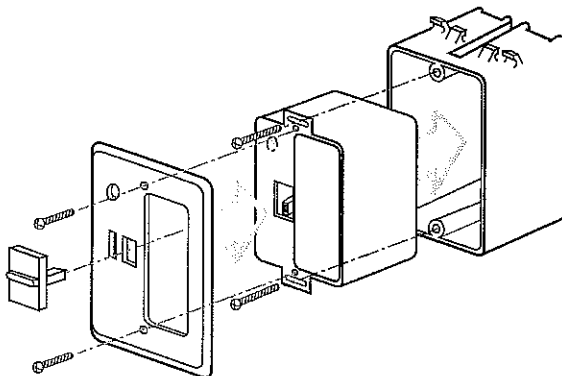

Figure 3

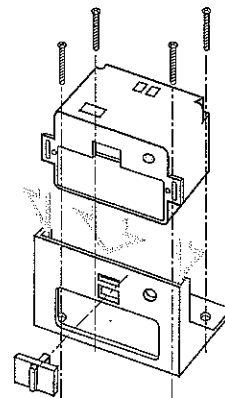

Figure 4

4 Installing the Remote Receiver to a Fireplace:

- Secure the Fireplace Mounting plate to the base pan of the fireplace.
- Slide the Remote Receiver into the fireplace mounting plate. See Figure 4.

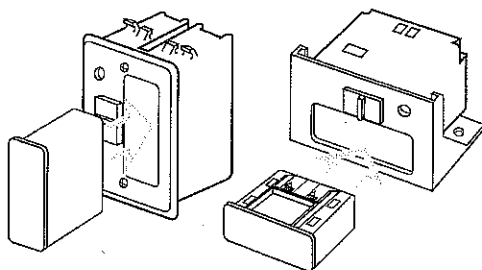

Figure 5

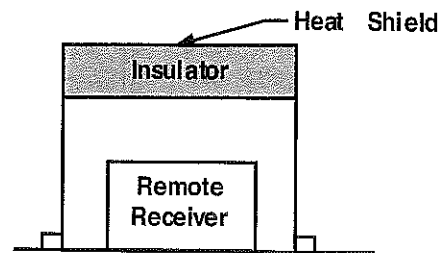

Figure 6

- 5 Put the switch cap to the slide switch.
- 6 Slide the battery compartment into the Remote Receiver. See Figure 5.
- 7 In order to prevent the Remote Receiver (fireplace installation only) from overheating, put a heat shield (option item) above the Remote Receiver. See Figure 6.

1.2 Installing the Remote Transmitter

- 1 Install the Wall Mount bracket horizontally onto the wall using the screws provided. See figure 7.
- 2 Slide the Wall Mount Programmable Transmitter onto the Wall Mount bracket as shown in figure 8.
- 3 Slide the battery compartment into the Wall Mount Programmable Transmitter as shown in figure 9.

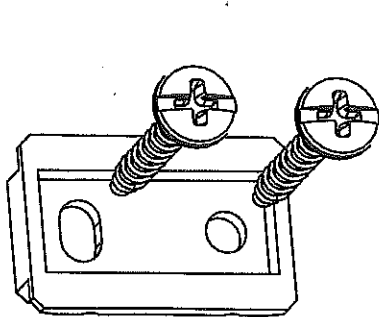

Figure 7

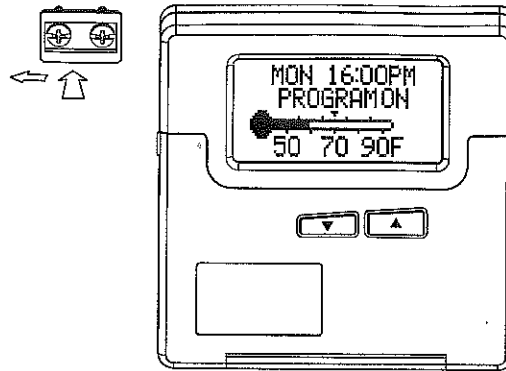

Figure 8

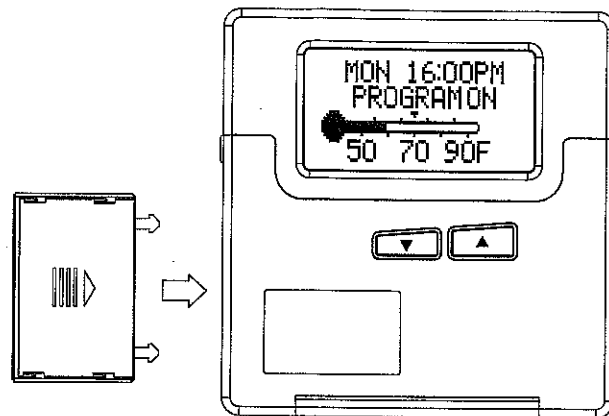

Figure 9

2.0 Operation Instructions:

2.1 Transmitter Operation

The WMT-06 Remote Control has 2 operating modes. They are: System ON and Manual on/off.

2.1.1 Program the Thermostat

- 1 Press the Prog INT button and then use the Up or Down buttons to choose NO and press the Enter button to skip adjusting clock.
- 2 Choose NO again (if necessary) to skip Vacation Override.
- 3 Then Choose YES for programming the thermostat.
- 4 Follow through the instruction at the LCD to program the Thermostat.
- 5 The System will automatically turn ON after you finish programming the thermostat.

2.1.2 Operation Modes

A. System On:

- 1 Press the PROG ON/OFF button to turn the system On. The Remote Control will automatically adjust the temperature when you are at home, away or sleep according to the program.
- 2 You may also use the Up or Down buttons to change the set temperature if desired.
- 3 Press the PROG ON/OFF button again to turn off the program.

B. Manual Mode:

- 1 Manual Mode can only be activated when the System is off.
- 2 Press the Manual On/Off button once to activate the Manual mode.

- 3 In Manual Mode the Remote Transmitter will automatically turn on the fireplace when the room temperature is below the set temperature and turn off the fireplace when the room temperature is above the target temperature.
- 4 Use the Up or Down buttons to adjust the set temperature.
- 5 Press Manual ON/OFF buttons to turn off the fireplace (if it is already on) and exit Manual Mode.

WARNING: IT TAKES SOME TIME FOR THE RECEIVER TO RESPOND TO THE TRANSMITTER. DO NOT PRESS THE MANUAL ON/OFF BUTTONS MORE THAN ONCE WITH 2 SECONDS FOR CORRECT OPERATION.

2.1.3 Vacation Override

- 1 Vacation Override can be activated to save energy when you are away. In Vacation Override the Remote Control will maintain the temperature at the "away temperature".
- 2 You can only activate the Vacation Override when the System is On.
- 3 Press the PROG INT button.
- 4 Use the Up and Down buttons to choose NO and then press the Enter button to skip adjusting clock.
- 5 Then Choose YES for Vacation Override.
- 6 Use the Up and Down buttons to set the number of days you are away. Then press the Enter button.
- 7 You can cancel the Vacation Override at anytime. Press the PROG INT button, then use the Up or down buttons to choose YES and press the Enter button to cancel the Vacation Override.

2.1.4. Child-Proof Function :

- 1 A CHILD-PROOF switch is on the back of the Remote Transmitter.
- 2 Slide the CHILD-PROOF switch to position marked C/P to activate the CHILD-PROOF function "C/P" will appear on the LCD. See figure 10.
- 3 In CHILD-PROOF the Remote Transmitter will continue to operate the fireplace, but the buttons will not be operable until C/P is removed.
- 4 Press the Up and Down buttons in the following sequence, Up-Down-Down-Up-Down, within 2 seconds button function will be temporarily restored, "C/P" will disappear from the LCD.
- 5 If no button is pressed within 2 minutes, the Remote Transmitter will return to Child-Proof function and "C/P" will reappear on the LCD.
- 6 To permanently remove C/P, slide the switch back to the other position.

2.1.5 Adjust Clock:

- 1 Press the PROG INT button, use the Up or Down buttons to choose YES then press the Enter button to adjust the clock.
- 2 Follow the instruction displayed on the LCD to adjust the clock.

2.1.6. Power Saving Mode:

- 1 There is a power saving mode in the Remote Transmitter. When "you are away or asleep" the Remote Transmitter will enter power saving mode.
- 2 In the power saving mode the Remote Transmitter will turn off the LCD. However all other functions in the Remote Transmitter will work normally.
- 3 When you press any button on the Remote Transmitter the LCD come back on.
- 4 The Remote Transmitter will go back to power saving mode afterward.
- 5 The Remote Transmitter will exit power saving mode when "you are awake or come back".

2.2 Receiver Operation

The Remote Receiver has 2 operation modes. They are On and Remote modes.

2.2.1. On Mode

- 1 In the On mode the Receiver will turn on the fireplace.
- 2 The Receiver will not respond to the Transmitter and turn the fireplace on and off.
- 3 In the On mode the receiver will not respond to the Remote Transmitter.

2.2.2. Remote Mode

- 1 The Receiver will respond to the Transmitter and turn the fireplace on and off accordingly.

2.3 Changing Batteries

- 1 The Remote Receiver uses 4 pieces AA-size batteries. Slide the slide switch at the Remote receiver to the Off position.
- 2 Press the battery compartment slightly into the Remote Receiver and then release. The battery compartment will pop out of the Remote Receiver.
- 3 Slide open the battery door and replace batteries.
- 4 Replace the battery door and slide the battery compartment back into the Remote Receiver.
- 5 The Remote Transmitter uses 3 AAA-size batteries. Replace these batteries at least every 6 months or when the Low battery indicator on the LCD is on.
- 6 Press the battery compartment slightly into the Remote Transmitter and then release. The battery compartment will pop out of the Remote Transmitter.
- 7 Slide open the battery door and replace batteries.
- 8 Replace the battery door and slide the battery compartment back into the Remote Transmitter.
- 9 After you take out the batteries, wait for at least 1 minute before putting fresh batteries into the Remote Transmitter and Receiver.
- 10 Use fresh alkaline batteries only.

WARNING: THE REMOTE TRANSMITTER WILL AUTOMATICALLY SWITCH OFF THE FIREPLACE WHEN THE BATTERIES IN THE REMOTE TRANSMITTER IS LOW.

3.0 IMPORTANT SAFETY FEATURE:

You can set a private code into your system to prevent accidental operation by another transmitter nearby. See Figure 10.

3.1 Coding Instructions:

- 1 There are code switches at the back of the Remote Transmitter. Slide the code switches to your choice of ON or OFF positions. FACTORY SETTING IS ALL "OFF".
- 2 Take the Remote Transmitter close to the fireplace or the Remote Receiver (less than 5 feet from the fireplace or Remote Receiver is recommended.)
- 3 Slide the slide switch on the Remote Receiver to Remote position.
- 4 Install fresh AAA alkaline batteries into the Remote Transmitter and choose YES to set code.
- 5 Press the Enter button on the Remote Transmitter. The Remote Receiver will produce a 'beep' sound when it receives the code from the Remote Transmitter. The system is now ready to operate.
- 6 If you do not hear a 'beep' sound from the Remote Receiver, remove batteries from the Remote Transmitter and slide the slide switch on the remote receiver to OFF position, wait for 1 minute, and repeat step 2 to 5.
- 7 If you desire to operate multiple Remote Receivers with the one Remote Transmitter, continue to hold the Enter button on the Remote Transmitter as you bring the Remote Transmitter within 5 feet of each Remote Receiver. Slide the slide switch on the Remote Receivers to Remote position. Each will acknowledge receipt of coding with a beep.

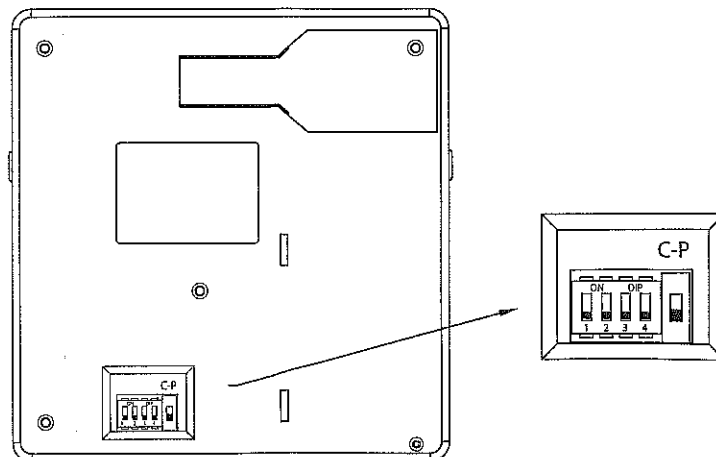

Figure 10